

# Mini Disk Infiltrometer

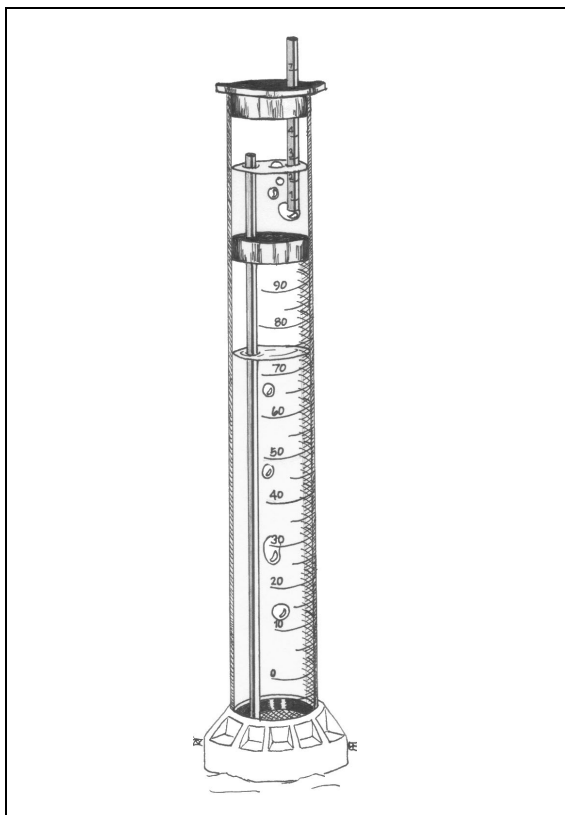

## User's Manual

Version 1.4

©2005 Decagon Devices, Inc.  
All rights reserved.

Decagon Devices, Inc.  
950 NE Nelson Court  
P.O. Box 835  
Pullman WA 99163

# Contents

<b>1. Introduction</b>	1
Welcome	1
Specifications	1
Contact Information	1
Warranty Information	1
<b>2. The Infiltrometer</b>	2
How it Works	2
Features	3
Hydraulic Conductivity	4
<b>3. Preparation</b>	6
Choosing the Suction Rate	8
Placement	9
<b>4. Collecting Data</b>	10
Use the Spreadsheet Macro	11
Calculate Infiltration	12
References:	14
Additional Reading	15
<b>5. Maintenance</b>	16
Cleaning	16
Suction tube	16

# **Minidisk Infiltrometer** User's Manual

## *Table of Contents*

---

# **1. Introduction**

---

## **Welcome**

Welcome to the mini disk infiltrometer for measuring soil hydraulic conductivity. The infiltrometer will enable you to measure the hydraulic conductivity of any soil accurately and affordably.

## **Specifications**

**Total Length - 32.7 cm**

**Diameter of tube- 3.1 cm**

**Sintered stainless steel disc: 4.5cm dia.,3 mm thick**

**Length of suction regulation tube: 10.2 cm**

**Suction range: 0.5 to 6cm of suction**

**Length of water reservoir: 21.2 cm**

**Length of Mariotte tube: 28cm**

**Volume of water required to operate: 135ml**

## **Contact Information**

To contact Decagon for customer support or questions:

- **E-mail us at [soils@decagon.com](mailto:soils@decagon.com)**
- **Send us a fax at: (509) 332-5158**
- **Call us at: 1-800-755-2751 (US and Canada only) or 509-332-2756.**

## **Warranty Information**

The infiltrometer has a 30-day satisfaction guarantee and a one-year warranty.

## **2. The Infiltrometer**

---

The mini disk infiltrometer is ideal for field measurements; due to its compact size, the water needed to operate it can easily be carried in a personal water bottle. It is also practical for lab and classroom use, in demonstrating basic concepts of soil hydraulic conductivity.

### **How it Works**

The upper and lower chambers of the infiltrometer are both filled with water. The top chamber (or bubble chamber) controls the suction. The lower chamber contains a volume of water that infiltrates into the soil at a rate determined by the suction selected in the bubble chamber. The lower chamber is labeled like a graduated cylinder, with volume shown in mL. The bottom of the infiltrometer has a porous sintered stainless steel disk which will not allow water to leak in open air. The small diameter of the disk allows for undisturbed measurements on relatively level soil surfaces.

Once you place the infiltrometer on a soil, water begins to leave the lower chamber and infiltrate into the soil at a rate determined by the hydraulic properties of the soil. As the water level drops, you record the volume at specific time intervals (like every 30 seconds for a silt loam soil). You can then plot this data using a spreadsheet (included on CD-ROM with the infiltrometer) to calculate the hydraulic conductivity.

## Features

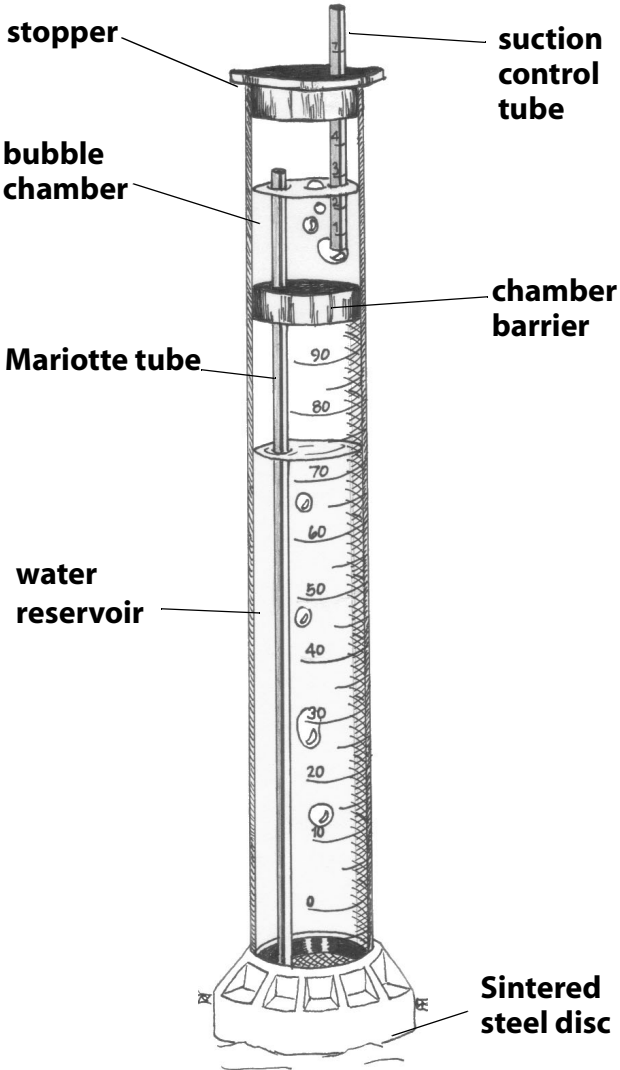

*Fig.1: Infiltrometer diagram*

## **Hydraulic Conductivity**

The mini disk infiltrometer measures the hydraulic conductivity of the medium it is placed upon. In *Principles of Soil and Plant Water Relations* by M.B. Kirkham (2005), hydraulic conductivity is defined as “the meters per day of water seeping into the soil under the pull of gravity or under a unit hydraulic gradient.” This is different than infiltration rate, which is defined as “the meters per unit time of water entering into the soil regardless of the types or values of forces or gradients.” Hydraulic conductivity is useful to scientists, land managers, and growers, in knowing how quickly water will infiltrate when applied to a given field or soil type. Infiltration is also relevant in fields of study such as contaminant transport, ground water recharge and ecosystem sustainability.

Because the infiltrometer has an adjustable suction (0.5 to 6 cm) you can get additional information about the soil by eliminating macropores with an air entry value smaller than the suction of the infiltrometer. This is done by controlling the infiltration with a small negative pressure or suction. When the water is under tension or suction, it will not enter macropores such as cracks or wormholes, but will only move into and through the soil as determined by the hydraulic forces in the soil.

Saturated conductivity is obtained when all the pores, including the large ones (such as cracks or wormholes), are filled. Macropore flow, however, is extremely variable from place to place, and therefore difficult to quantify. Infiltrating water under a tension prevents the filling of the macropores and gives a hydraulic conductivity characteristic of the soil matrix, and is less spatially variable.

Soil Hydraulic Conductivity is a function of water potential and water content of the soil. The decrease in conductivity as the soil dries is due primarily to the movement of air into the soil to replace the water. As the air moves in the pathways for water flow between soil particles becomes smaller and more tortuous, and flow becomes more difficult.

## 3.Preparation

To prepare the infiltrometer for measurement, do the following:

1. Fill the bubble chamber by running water down the suction control tube or removing the upper stopper as shown. *Note: Do not use distilled water. Soil water has solutes and clays have salts on the exchange sites. Using distilled water changes the ionic balance and may flocculate or disperse the clay in the soil.*

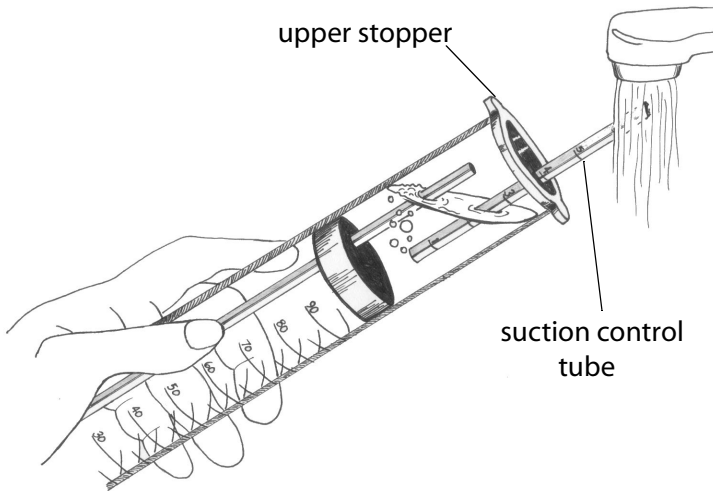

*Fig. 2: Filling the upper chamber*

2. Once the upper chamber is full, slide the suction control tube all the way down, invert the infiltrometer, remove the bottom elastomer with the porous disk, and fill the water reservoir.

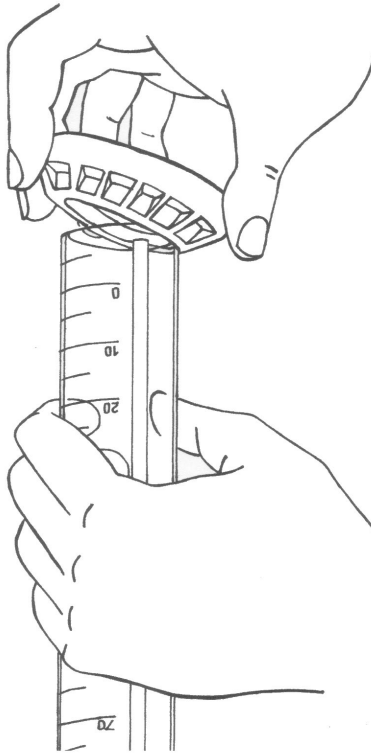

*Fig. 3: Removing the bottom elastomer*

3. Replace the bottom elastomer, making sure the porous disk is firmly in place.

## **Choosing the Suction Rate**

Since different soil types will infiltrate water at different rates, measuring the change of volume vs. time can often be difficult, particularly in a sandy soil where the water will infiltrate rapidly. Therefore, you can adjust the suction rate to better accommodate measuring infiltration for the type of soil you are measuring. **For most soils, a suction rate of 2cm should be adequate.** In particularly sandy soils where infiltration will occur very quickly, an adjustment to 6cm may be helpful, and for more compact soil where infiltration is much slower, a suction rate of 0.5 is recommended. However, we generally recommend that adjusting the suction to rates other than 2cm should be reserved to more advanced users who are comfortable with the instrument and theory of operation.

To adjust the suction rate, move the suction tube up or down so the water level is even with the desired suction rate marked on the side of the tube. If the suction tube is difficult to move, apply a small amount of vacuum grease on the tube to ease movement. Small suctions allow large pores to fill; large suctions allow only small pores to fill.

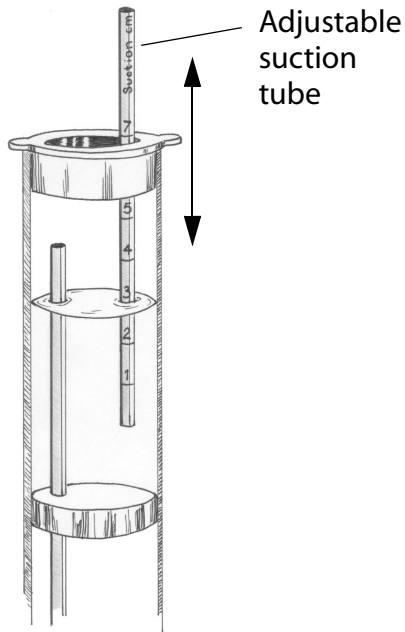

*Fig. 4: Upper chamber and suction tube*

4. If the infiltrometer is held vertically, no water should leak out.

## **Placement**

The infiltrometer should be applied to a smooth spot on the soil surface. If the surface is not smooth, a thin layer of fine silica sand or diatomaceous earth can be applied to the area directly underneath the infiltrometer's stainless steel disk. This will ensure good contact between the soil and the infiltrometer. When possible, we also recommend using a ring stand and clamp to hold the infiltrometer in place.

## 4. Collecting Data

To make the hydraulic conductivity measurement, make sure you have first prepared the instrument as described in the previous chapter. Then do the following:

1. Record the starting water volume.
2. At time zero, place the infiltrometer on the surface, assuring that it makes solid contact with the soil surface.
3. Record volume at regular time intervals as the water infiltrates. The time interval you choose is based on both the suction rate you select and the soil type being measured. For example, a sand will typically be 2-5 seconds between readings, a silt loam every 30 seconds, and a tight clay 30 to 60 minutes. A typical data set will look like the first and third columns of Table 1.

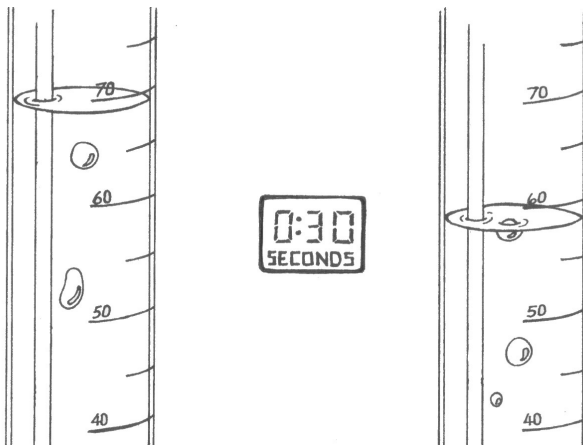

*Fig. 5: Timed infiltration*

**Table 1: Sample infiltrometer data**

Time (s)	sqrt (t)	Volume (mL)	Infiltration (cm)
0	0.00	95	0.00
30	5.48	89	0.39
60	7.75	86	0.58
90	9.49	83	0.77
120	10.95	80	0.97
150	12.25	77	1.16
180	13.42	75	1.29
210	14.49	73	1.42
240	15.49	71	1.55
270	16.43	69	1.68
300	17.32	67	1.81

## **Use the Spreadsheet Macro**

Your infiltrometer was shipped with a CDROM containing a basic Microsoft Excel<sup>®</sup> spreadsheet. This spreadsheet will calculate the slope of the curve of the cumulative infiltration vs. the square root of time based on the data gathered in the above steps. To use this spreadsheet, first make sure that your PC has Microsoft Excel installed. Then do the following:

1. Open the file. You will see a table similar to the one above.
2. Input the volume levels you recorded into the corresponding volume column, and correlated with the time column on the left. You may need to extend the columns depending on how much data you have recorded. The square root of time column and infiltration column will change automatically based on your data, and the graph on the right of the table will update to reflect the changes.
3. Save the data as a new spreadsheet on your hard drive.

## Calculate Infiltration

A number of methods are available for determining soil hydraulic conductivity from these data. The method proposed by Zhang (1997) is quite simple, and works well for measurements of infiltration into dry soil. The method requires measuring cumulative infiltration vs. time and fitting the results with the function

$$I = C_1 t + C_2 \sqrt{t} \quad (1)$$

where  $C_1$  ( $\text{m s}^{-1}$ ) and  $C_2$  ( $\text{m s}^{-1/2}$ ) are parameters.  $C_1$  is related to hydraulic conductivity, and  $C_2$  is related to soil sorptivity. The hydraulic conductivity of the soil ( $k$ ) is then computed from

$$k = \frac{C_1}{A} \quad (2)$$

where  $C_1$  is the slope of the curve of the cumulative infiltration vs. the square root of time, and  $A$  is a value relating the van Genuchten parameters for a given soil type to the

suction rate and radius of the infiltrometer disk.  $A$  is computed from:

$$A = \frac{11.65(n^{0.1} - 1) \exp[2.92(n - 1.9)\alpha h_o]}{(\alpha r_o)^{0.91}} \quad n \geq 1.9 \quad (3)$$

$$A = \frac{11.65(n^{0.1} - 1) \exp[7.5(n - 1.9)\alpha h_o]}{(\alpha r_o)^{0.91}} \quad n < 1.9$$

where  $n$  and  $\alpha$  are the van Genuchten parameters for the soil,  $r_o$  is the disk radius, and  $h_o$  is the suction at the disk surface. The mini disk infiltrometer infiltrates water at a suction of -0.5 to -6 cm and has a radius of 2.2 cm. The van Genuchten parameters for the 12 texture classes were obtained from Carsel and Parrish (1988). Values of  $A$  computed for the mini disk infiltrometer are given in Table 2.

**Table 2: van Genuchten parameters for 12 soil texture classes and  $A$  values for a 2.2 cm disk radius and suction values from 0.5 to 6 cm.**

Texture	$\alpha$	$n$	$h_o$						
			-0.5	-1.0	-2.0	-3.0	-4.0	-5.0	-6.0
			$A$						
sand	0.145	2.68	2.9	2.5	1.8	1.3	0.9	0.7	0.5
loamy sand	0.124	2.28	3.0	2.8	2.5	2.2	1.9	1.6	1.4
sandy loam	0.075	1.89	4.0	4.0	4.0	4.0	4.0	4.1	4.1
loam	0.036	1.56	5.6	5.8	6.4	7.0	7.7	8.4	9.2
silt	0.016	1.37	8.1	8.3	8.9	9.5	10.1	10.8	11.5
silt loam	0.020	1.41	7.2	7.5	8.1	8.7	9.4	10.1	10.9
sandy clay loam	0.059	1.48	3.3	3.6	4.3	5.2	6.3	7.6	9.1
clay loam	0.019	1.31	6.0	6.2	6.8	7.4	8.0	8.7	9.5
silty clay loam	0.010	1.23	8.1	8.3	8.7	9.1	9.6	10.1	10.6
sandy clay	0.027	1.23	3.4	3.6	4.2	4.8	5.5	6.3	7.2
silty clay	0.005	1.09	6.2	6.3	6.5	6.7	6.9	7.1	7.3
clay	0.008	1.09	4.1	4.2	4.4	4.6	4.8	5.1	5.3

4. A quadratic equation is included in the Excel spreadsheet. Columns 2 and 4 from the table are used to produce an XY (scatter) plot to the right of the table. This is used to calculate  $C_1$ , which is the slope of this line, denoted as “y.” An example is shown in the graph below:

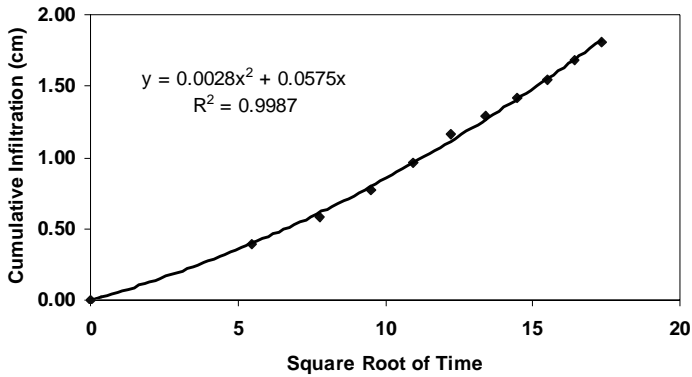

In this example, the value of  $C_1$  is  $0.0028 \text{ cm s}^{-1}$ . The soil is a silt loam, so from Table 2, for  $-2 \text{ cm}$  suction,  $A = 8.1$ . The hydraulic conductivity (at  $2 \text{ cm}$  suction) is therefore  $k = 0.0028 \text{ cm s}^{-1} / 8.1 = 3.45 \times 10^{-4} \text{ cm/s}$ .

A much more extensive discussion of tension infiltrometer measurement and analysis is given in Dane and Topp (2002) p. 888-896.

## References:

- Carsel, R. F. and R. S. Parrish. 1988. "Developing joint probability distributions of soil water retention characteristics." *Water Resour. Res.* 24: 755-769.

Dane, J. H. and G. C. Topp, Eds. (2002) *Methods of Soil Analysis Part 4 - Physical Methods*. Soil Science Society of America, Madison, WI.

Kirkham, M.B. (2005) *Principles of Soil and Plant Water Relations*. Elsevier Academic Press: Burlington, MA. pp. 145-172.

Zhang, R. 1997. "Determination of soil sorptivity and hydraulic conductivity from the disk infiltrometer." *Soil Sci. Soc. Am. J.* 61: 1024-1030.

## **Additional Reading**

Clothier, B.E. (2001) "Infiltration." *Soil and Environmental Analysis*. Edited by Keith A. Smith and Chris Mullins.

## **5. Maintenance**

---

### **Cleaning**

All of the infiltrometer parts can be cleaned using mild soap and water. The stainless steel disk can be cleaned with a brush or even run in a dishwasher. Since it is stainless steel, it will not rust, cleans easily, and won't snag or tear on rags when washing.

### **Suction tube**

If the suction regulation tube is difficult to move, use a small amount of vacuum grease to allow it to move more freely.